









NOTE: THIS DRAWING IS PROPRIETARY INFORMATION OF THE PRISON INDUSTRY AUTHORITY AND IS NOT TO BE DISCLOSED IN PART OR AS A WHOLE WITHOUT PRIOR WRITTEN CONSENT AND PERMISSION OF THE PRISON INDUSTRY AUTHORITY.

**CAD-DRAWING**  
 THIS DRAWING WAS CREATED ON A COMPUTER AIDED DESIGN (CAD) SYSTEM. TO INSURE THE INTEGRITY OF THE DATA BASE, ALL CHANGES/ REVISIONS MUST BE MADE ON THE CAD SYSTEM.

REVISION	DATE
A	11/18/2019

**TOOLS REQUIRED:**

-  FLAT SCREWDRIVER
-  PHILLIPS SCREWDRIVER
-  PRY BAR
-  ADJUSTABLE PLIERS
-  RUBBER Mallet
-  UTILITY KNIFE
-  PUTTY KNIFE
-  PERSONAL PROTECTIVE EQUIPMENT (PPE)

**MATERIAL TYPE:**

- ① STEEL
- ② ALUMINUM
- ③ FABRIC
- ④ PLASTIC
- ⑤ GLASS
- ⑥ FIBERGLASS
- ⑦ FIBERBOARD
- ⑧ WOOD

**PROCEDURE:**

- 1) PLACE TABLE UPSIDE DOWN.
- 2) REMOVE FASTENERS CONNECTING LEGS TO TABLE TOP AND CROSS RAILS.
- 3) REMOVE FOUR EDGE BAND PIECES FROM TABLE TOP.
- 4) REMOVE & SORT FASTENERS BY MATERIAL TYPE.

**GENERAL NOTES:**

- 1) DISASSEMBLY TIME 30-40 MINUTES
- 2) THIS PROCEDURE ASSUMES BASIC FAMILIARITY WITH HAND TOOLS AND FURNITURE TERMINOLOGY: NO SPECIALIZED TRAINING IS REQUIRED.
- 3) ALL MATERIAL REMOVED AND DISASSEMBLED SHALL BE SORTED AND SEGREGATED WITH LIKE MATERIALS AND DISPOSED OF OR RECYCLED ACCORDING TO RECYCLING AVAILABILITY OR WASTE ACCEPTANCE.
- 4) FOR ITEMS TO BE RECYCLED, REFER TO CALPIA WEBSITE AT [WWW.CALPIA.CA.GOV](http://WWW.CALPIA.CA.GOV).

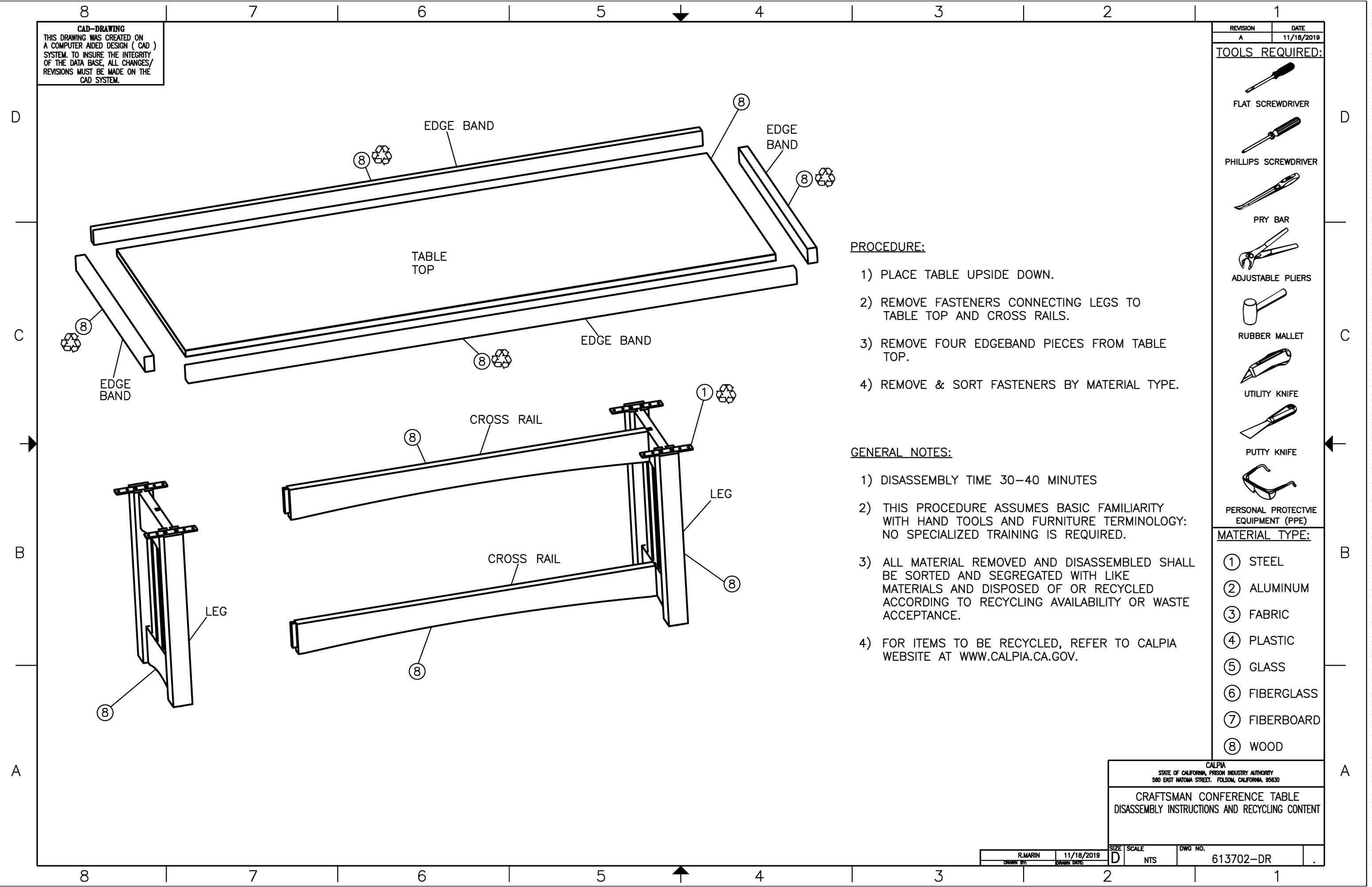

CALPIA  
 STATE OF CALIFORNIA, PRISON INDUSTRY AUTHORITY  
 580 EAST NATOMA STREET, FOLSOM, CALIFORNIA 95630

**CRAFTSMAN CONFERENCE TABLE**  
 DISASSEMBLY INSTRUCTIONS AND RECYCLING CONTENT

SIZE	SCALE	DWG. NO.
D	NTS	613702-DR

DRAWN BY:	R.MARIN	DATE:	11/18/2019
-----------	---------	-------	------------