

CALPIA Disassembly Instructions for Boston 24/7 - Page 1

****Items are listed in suggested order of disassembly - Estimated Time Required - 25 minutes**

STEP	DESCRIPTION	QTY	MATERIAL(S)		TOOL	PROCEDURE
1	Back Connector Bolt	2	Steel	Y	B	Using a wrench, remove the nuts securing the back connector on the top side of the mechanism, then the bolts on the bottom side of the mechanism
2	Back Connector to Back Bolt	4	Steel	Y	C	Using an Allen Key, remove the 4 bolts which attach the back connector to the back
3	Back Connector	1	Plastic (GFN) ♻️ (7)	Y	NA	Recycle
4	Back	1	Plastic (Nylon and ABS) ♻️ (7)	Y	A, C	Remove Allen Bolts on the rear of back to separate inner and outer components. Use a screwdriver to remove the mesh and clips from the inner back
5	Headrest	1	Various *			SEE PAGE 2 FOR DISASSEMBLY DETAILS
6	Lumbar	1	Various *			SEE PAGE 2 FOR DISASSEMBLY DETAILS
7	Arm Bolts	8	Steel	Y	A	Remove the bolts attaching the arms to seat
8	Arm Pad Bolts & Arm Pad	4	Steel & Polyurethane Foam*	Y	A	Remove the bolts holding arms to arm pads. Set aside arm pad for recycling
9	Arm Plate	2	Steel	Y	NA	Use a wrench to remove nuts holding the plate on.
10	Arm	2	GFN and Steel, Aluminum * ♻️ (7)	Y	B	
11	Mechanism Bolt	4	Steel	Y	A	Remove 4 bolts connecting mechanism to the seat
12	Outer Seat	1	Plastic (GFN) ♻️ (7)	Y	A	Using a screwdriver, pry inner and outer seat apart
13	Reinforcement Plate	1	Steel	Y	NA	Recycle
14	Inner Seat	1	Plastic (PP) ♻️ (5)	Y	E, F	Cut upholstery from seat plastic using knife and remove staples using pliers
15	Seat Foam	1	PU Foam	Y	E	Cut or steam seat foam from plastic seat
16	Mechanism Covers	3	High Impact Polystyrene ♻️ (6)	Y	HAND	Remove main and side covers from mechanism. It may be necessary to break the main cover to remove it from the mechanism
17	Mechanism	1	Steel and Plastic (Nylon) * ♻️ (7)	Y	D	Using a hammer, tap the steel of the mechanism beside the gas lift until it dislodges
18	Gas Lift	1	Steel, Rubber, Plastic (Nylon) * ♻️ (7)	Y	D	Using a hammer, tap the bottom of the gas lift to dislodge it from the chair base.
19	Cover Can	1	Plastic (PP) ♻️ (5)	Y	HAND	Slide plastic cover can off of gas lift
20	Chair Base	1	Cast Aluminum	Y	C, D	Remove casters from base by pulling downward on them while securely holding the chair base. Then use Allen key to remove screws of base bottom cover, then use hammer to remove anti-slip covers
21	Casters	5	Plastic (Nylon) and Steel * ♻️ (7)	Y	HAND & F	The metal posts on the casters can be pulled out by gripping the plastic portion of the caster and pulling on the metal stem with pliers

* part is comprised of co-mingled materials. Contact your recycling facility

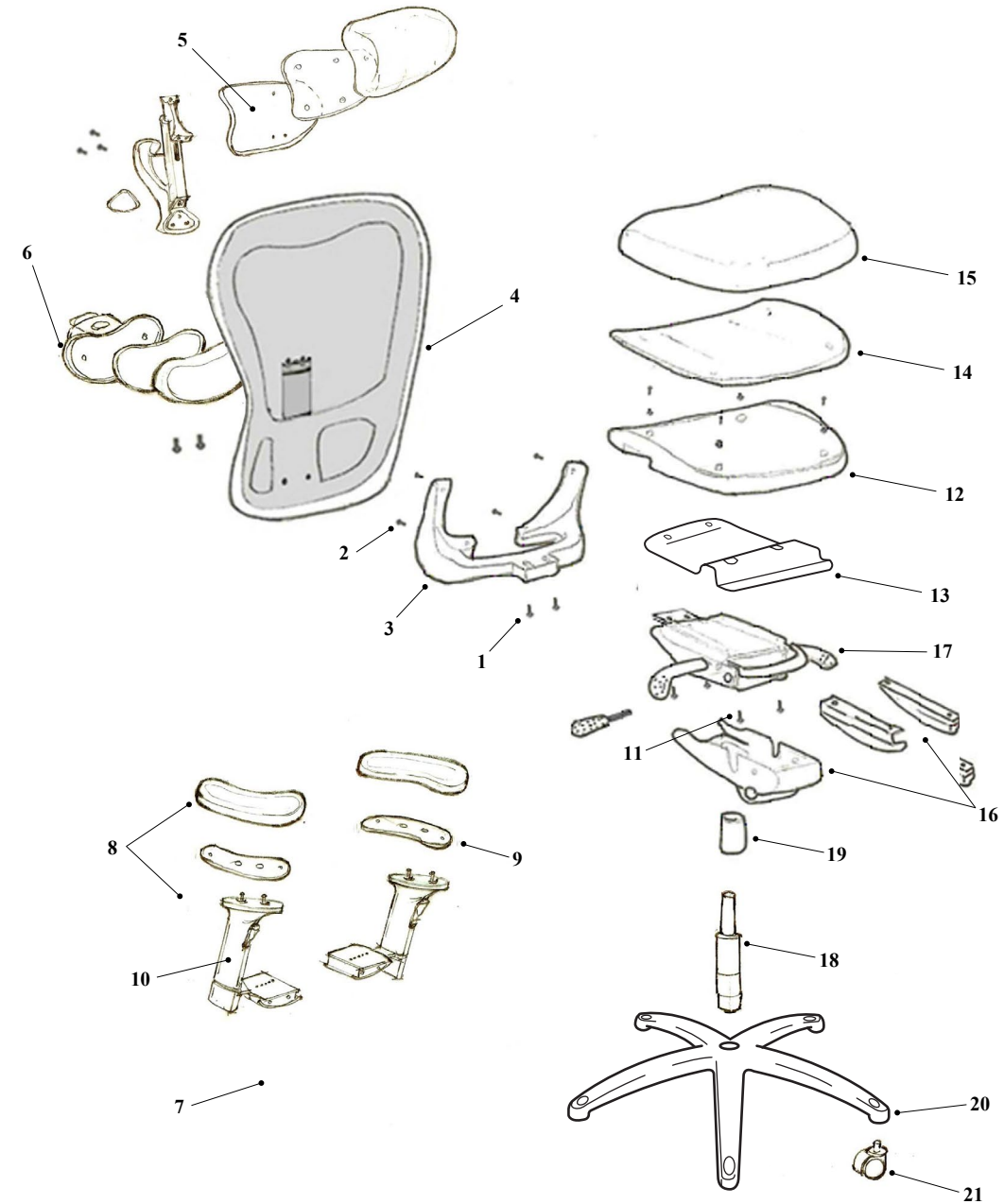

A. Screwdriver



B. Wrench



C. Allen Key



D. Hammer



E. Knife



F. Pliers

Caution

Proper safety equipment should be worn when attempting to disassemble any Nightingale product. Dependent on state of wear, products may have exposed sharp edges. Nightingale accepts no responsibility for any damage, accident or injury which may occur during disassembly. For further assistance, please contact Customer Service at Nightingale 1-800-363-8954